

MDV Family

MDV1000 Series

Multi-purpose compact DC/DC converters



Description

Compact isolated DC/DC converters of MDV Series for industrial and special purpose applications. Despite the small size (168×110×16 mm) the maximum output power of modules reach up 1000 W and they are able to operate in a wide case operating temperature range (–60...+125°C). These modules might have single galvanically isolated output, remote on/off, short circuit, overcurrent and thermal protection and can operate in parallel and series modes. Without optocouplers in the converter's circuit it can safely operate in conditions of ionizing radiation and high temperature. Power supplies have variable protections from different factors: vibration, dirt, moisture fog and salt fog.

These modules undergo special thermal and limit test including burn-in test with extreme on/off modes.

Compliance

- MIL-STD-810G
- MIL-STD-461F (CE102)
- MIL-STD-704E



Description of MDV Family on the manufacturer's website
eng.aedon.ru/pr-universal.php

Features

- 5 year warranty
- Output current up to 40 A
- 28 VDC (index "V") input compliant with MIL-STD-704E
- Low-profile design (16 mm) with cylindrical pin outs
- Case operating temperature –60...+125°C
- 125 °C baseplate operation without derating
- Magnetic feedback without optocouplers
- Short circuit protection, overvoltage, thermal protection
- Remote on/off
- Output voltage adjustment
- Typical efficiency 89% (Uout.=24 VDC)
- Polymer potting sealing

Order registration

+7 473 200 87 80, Global Operations Team

Technical support

techsup@aedon.ru

Reliability test

eng.aedon.ru/downloads/documentation/Reliability-Test_ENG.pdf

3D models

www.aedon.ru/content/catalog/docs/207/MDM1000V.zip

Ordering information

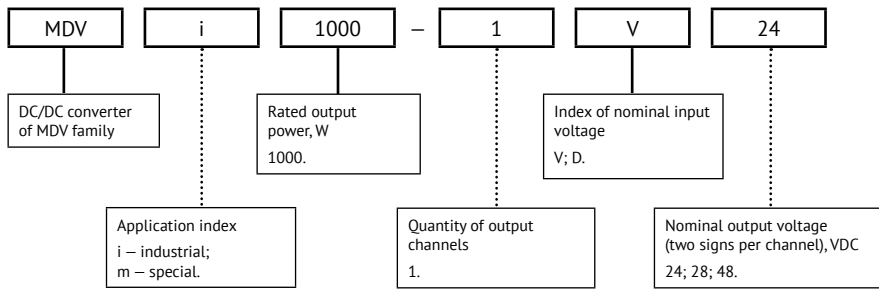

For more information please contact our Global Operations Team

+7 473 200 87 80
info@npo-enel.ru

Application index

Parameter		Index "m"	Index "i"
Case operating temperature		-60...+125°C	-40...+85°C
Compliance	MIL-STD-810G	+	-
	EN60950-1	+	
	MIL-STD-461F	CE102	
	MIL-STD-704E	28 VDC input (index "V")	
Total regulation (Inom 10–100%)		±6%	±4%
Vibration proof		+	-
Moisture proof (Tamb.=25°C)		98%	60%
Dust proof		+	-
Salt fog resistant		+	-
Typical MTBF		2 000 000 hrs	500 000 hrs
Failure rate		<0,05%	<1%
Warranty		5 years	3 year

Rated output power and current

Power	1000 W		
Output voltage, VDC	24	28	48
Rated output current, A	40	35,7	20,8

Index of nominal input voltage*

Parameter	Index "V"	Index "D"
Nominal input voltage, VDC	28	48
Input voltage range, VDC	17...36	36...75
Transient deviation (1 s), VDC	17...80	36...84
Typical efficiency for Uout.=24 VDC	88%	89%

* Reflected input ripple current (10–10000 Hz) – 8% Uin. nom

Specifications

All specifications valid for normal climatic conditions (ambient temp. 15...35°C; relative humidity 45...80%; air pressure 8,6*10⁴...10,6*10⁴ Pa), U_{in}. nom, I_{out}. nom, unless otherwise stated. It is important to note that the information herein is not full. More detailed information (specific requirements, basic connection circuits, operating instructions etc.) can be found on our web-site: eng.aedon.ru

Output specifications

Parameter		Value
Output voltage adjustment of single channel models		5% U _{out} . nom
Total regulation	Input voltage variation (U _{min} ...U _{max})	max ±2%
	Load variation (10...100% I _{max})	
Ripple and noise (p-p)		<2% U _{out} . nom
Maximum capacitive load	24 VDC	470 uF
	48 VDC	220 uF
Start up time (remote)		max 0,1 s
Overload protection level*		<1,8 P _{max}
Short circuit protection*		hiccup auto recovery
Overvoltage protection		1,5 U _{nom}

* Parameters are stated for the information purposes and could not be used at long term work, exciding maximum output current, at work outside of a range of operating temperatures.

General specifications

Parameter		Value
Case temperature	Operating (natural convection) – power derating (natural convection) – without power derating with heatsink	–60...+125°C see power derating diagram (dashed, dash-dotted curve) see power derating diagram (solid curve)
	Storage	–60...+125°C
Switching frequency		130–150 kHz
Isolation capacitance	input/output	1500 pF
Isolation voltage (60 s)	input/output, input/case, output/case	500 VAC
Isolation resistance @ 500 VDC	input/output, input/case, output/case	20 MOhm min
Thermal impedance		2,7°C/W
Thermal protection level		118...125°C, clamp, auto recovery
Remote on/off		Off.: connection of pins "ON" and "–IN", I _s 5 mA

Specifications (cont.)

Physical specifications

Parameter	Value
Case material	aluminium
Potting	epoxy polimer
Pin material	phosphor bronze, SnP8 plated
Weight	max 690 g
Soldering temperature	260°C @ 5 s

Design topology

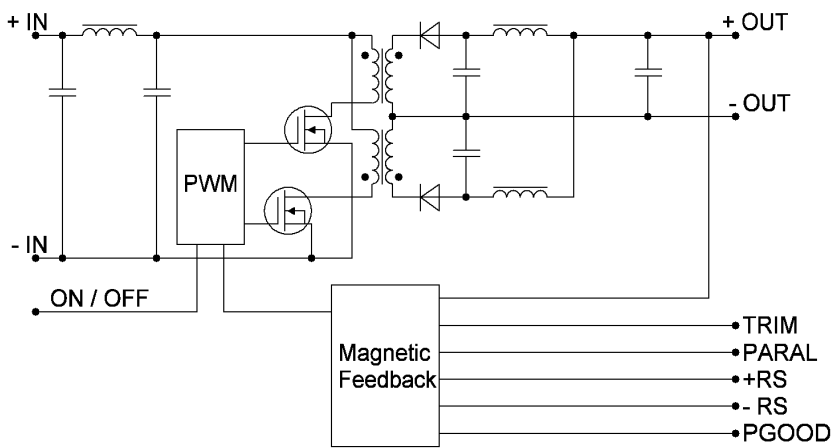

Figure 1. Design topology.

Service functions

Typical connection

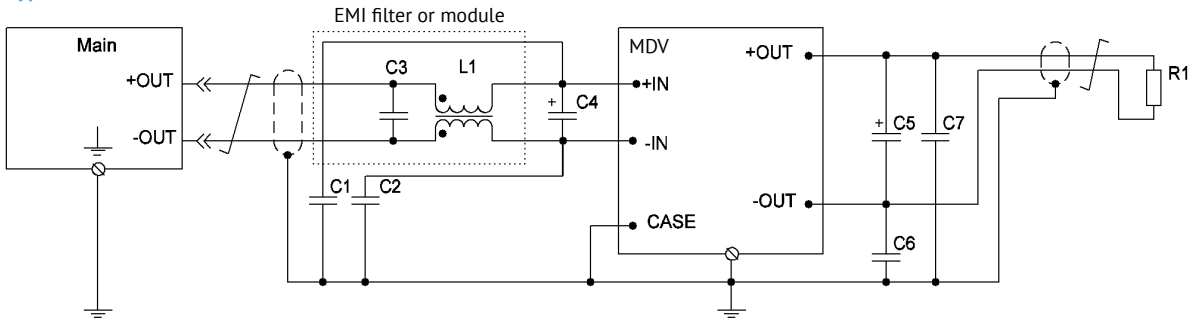

Figure 2. Design topology with filtration unit.

C1, C2, C6, C7		ceramic capacitor		100...4700 pF 500 VDC min
C4		tantalum capacitor	Input voltage	12 VDC 24 (28) VDC
C5		tantalum capacitor	Output voltage	5 VDC 12 VDC 24 VDC 48 VDC
EMI Filter	L1	common mode choke		8 mH
	C3	ceramic capacitor	Input voltage	12 VDC 24 (28) VDC
EMI Module	M series	Double Pi filter EMI module. See datasheet M Series	Maximum current up to 20 A, overvoltage and surge protection, loss insertion up to 60 db	

Service functions (cont.)

Remote control

Function of remote control by a signal allows to control the unit's operation using mechanical relay or electric switch of "open collector" type.

The unit should be powered off by connecting "ON" output to "-IN" output. The switch can carry current of up to 5 mA, the max voltage drop on the switch should be less than 1,1 V.

The unit is powered on by disconnecting the switch within the time less then 5 μ s. Being disconnected the switch is applied by approximately 5 V, allowable current leakage through the switch should not be over 50 μ A.

To arrange remote power off/on of several units simultaneously it is not allowed to use additional elements in the circuit to connect outputs "ON" and "-IN" and a switch.

If the function of remote power off/on is not used, "ON" output is allowed to be left unconnected.

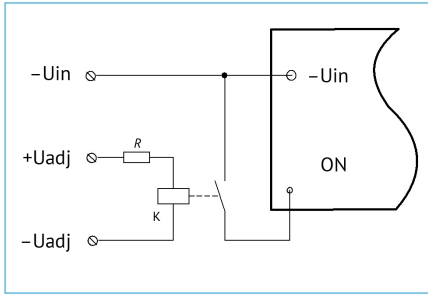

Figure 3 (a). Layout of mechanical relay control.

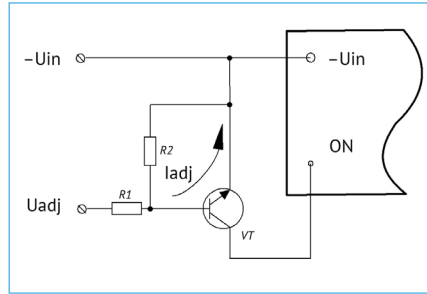

Figure 3 (b). Layout of bipolar transistor control.

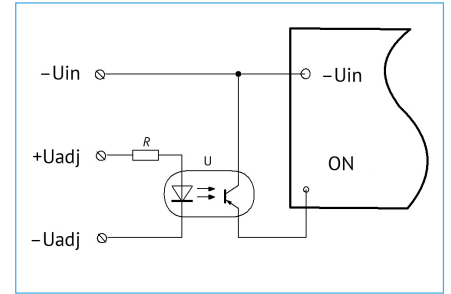

Figure 3 (c). Layout of optocoupler control.

Adjustment

Adjustment of output voltage of a power supply unit within the range of at least $\pm 5\%$ can be done by connecting "TRIM" output (if available) through "-OUT" output to increase output voltage, or through "+OUT" output to decrease the output voltage.

In case of using variable resistor Rvar and outside resistors (R1, R2) it is possible to fulfill the adjustment both to increase and decrease the output voltage.

If you need to control the output voltage of a power supply unit by a signal from external source of current or voltage, e.g. in micro-controller automated control systems using DAC, the external current or voltage signal should be supplied to the adjustment output relating to "-OUT" output, as shown in the drawings (b) and (c).

Calculation formula of nominal values of circuit elements (a), current (b) and voltage (c) can be found in Technical Guides available on www.eng.aedon.ru.

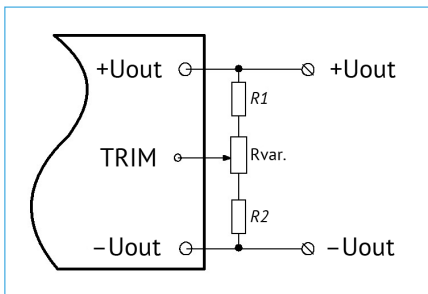

Figure 4 (a).

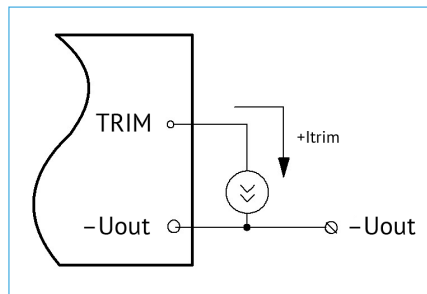

Figure 4 (b).

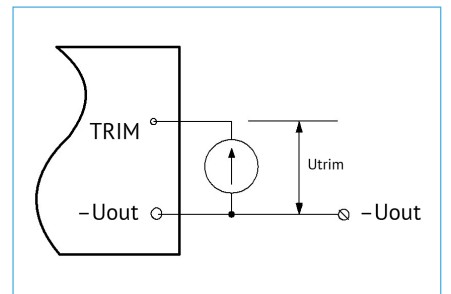

Figure 4 (c).

Efficiency

VS load

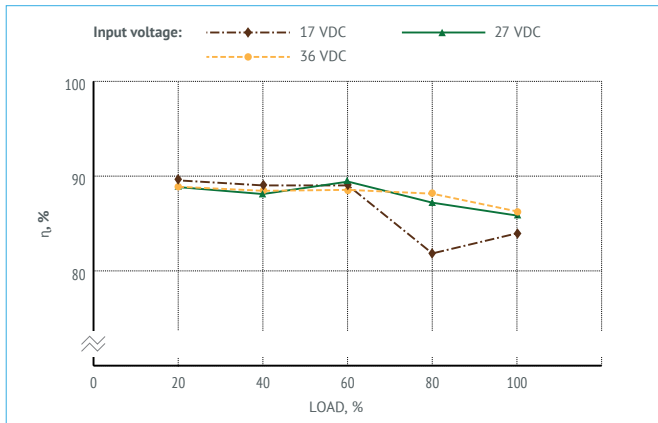

Figure 5. Efficiency of MDV1000-1V28.

Power derating

VS ambient temperature and baseplate temperature

The PSU is able to operate with 100% load within the complete range of case operating temperature (−60...+125 °C). On condition the case temperature is kept from −60°C to 125 °C the PSU will operate without derating regardless of the ambient temperature. Thermal Management section of the Application Notes shows the resulting heatsink area, as well as baseplate-vs-ambient thermal resistance, the min thickness of the heatsink, and the max PSU output power without heatsink.

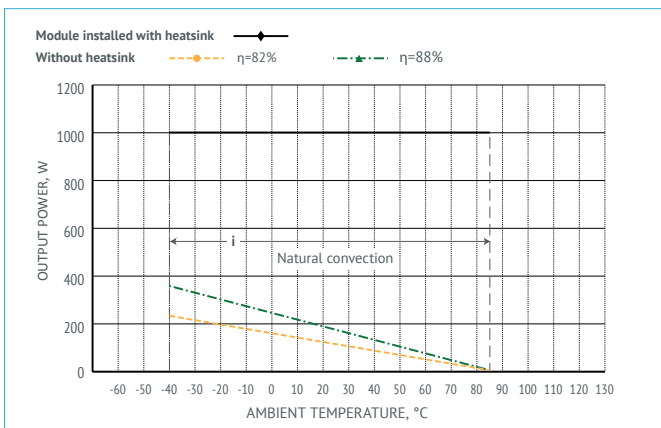

Figure 6 (a). Power derating of MDVi1000-xxx.

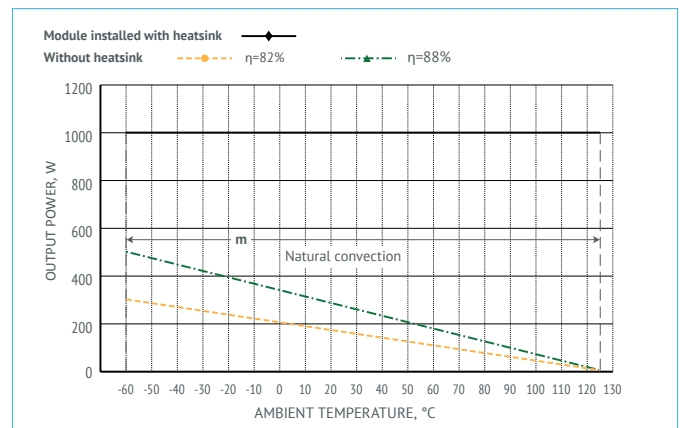

Figure 6 (b). Power derating of MDVm1000-xxx.

Oscillograph charts of MDV1000-xxx

Testing conditions $U_{in}=28$ VDC, $I_{out}=30$ A, $T_{amb}=25$ °C, $U_{out}=24$ VDC, $C_{out}=100$ μ F

The database of regulated parameters of the manufactured products is available. Pls. contact your personal manager or customer support service to get necessary information.

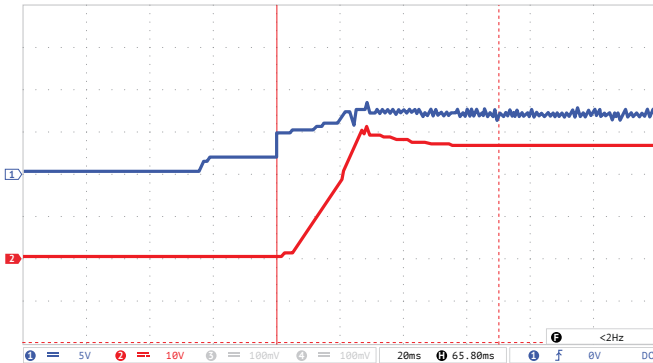

Figure 7 (a). Oscillograph chart of setting output voltage after supplying remote control signal to ON-output.

Ray 1 (blue) – voltage at ON-output. Scale 5 V/div.

Ray 2 (red) – output voltage. Scale 10 V/div.

Time scale $t=20$ ms/div.

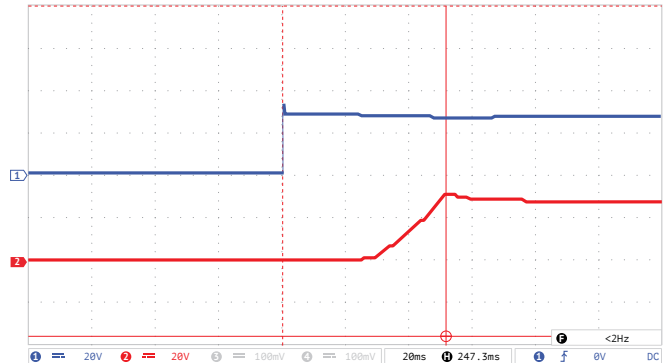

Figure 7 (b). Oscillograph chart of output voltage after supplying the input voltage.

Ray 1 (blue) – input voltage. Scale 20 V/div.

Ray 2 (red) – output voltage. Scale 20 V/div.

Time scale $t=20$ ms/div.

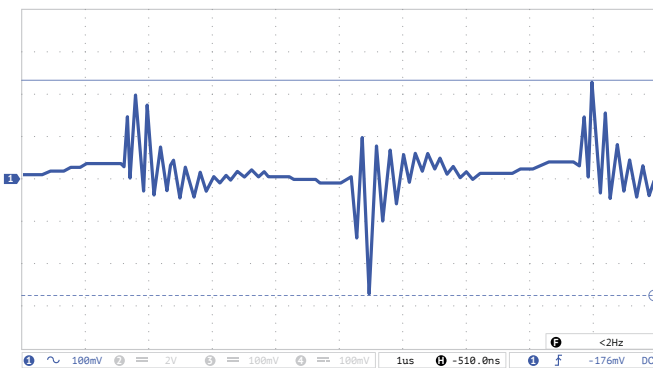

Figure 7 (c). Oscillograph chart of output voltage ripple.

Ray 1 (blue) – ripple of output voltage. Scale 100 mV/div.

Time scale 1 μ s/div.

Measuring technique: see Electrical Test Screen.

Outline dimensions

Models packed in reinforced case with flanges

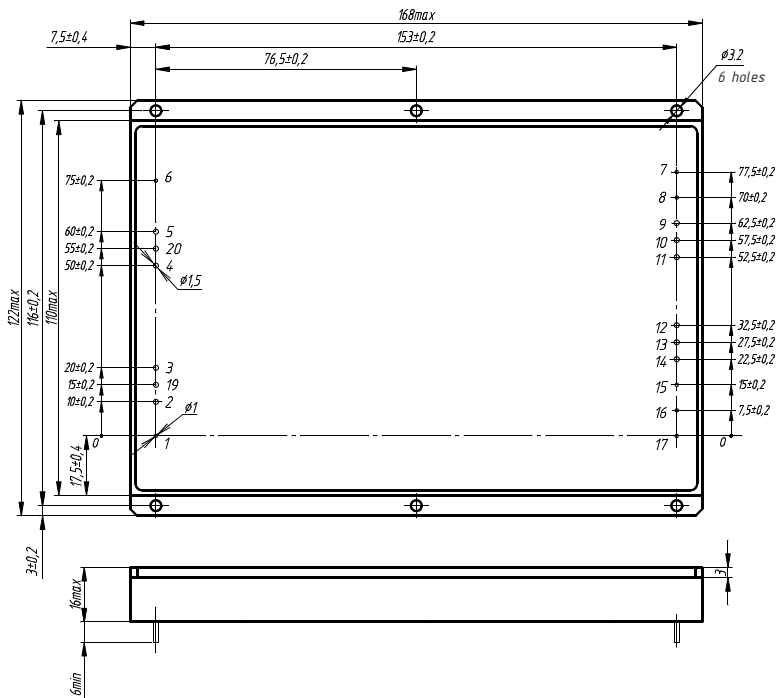

Figure 8. Single-output models.

Pin out

Pin #	1	2, 3, 19	4, 5, 20	6	7	8	9, 10, 11	12, 13, 14	15	16	17	18
Function	ON	-IN	+IN	CASE	PGOOD	+RS	+OUT	-OUT	-RS	TRIM	PARAL	NO PIN

Accessories

Heatsink

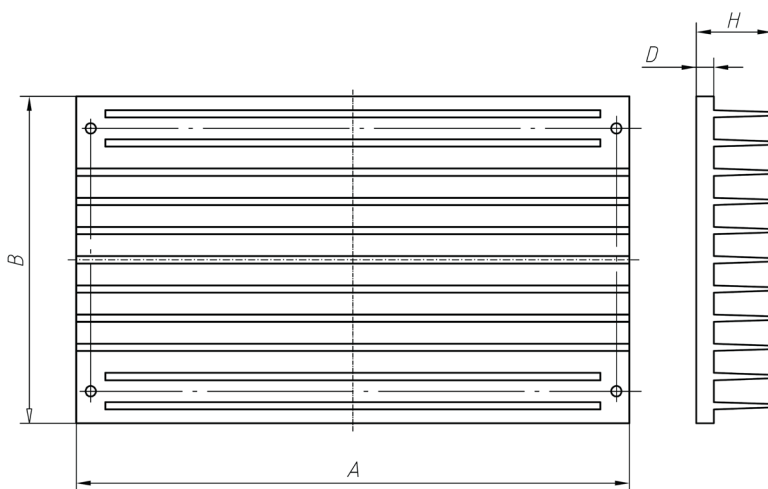

Figure 9. Heatsink with longitudinal ribs 168×125×45×6 mm (A×B×H×D).



eng.aedon.ru

mail@aedon.ru

AEDON, LLC is the leading Russian developer and manufacturer of DC/DC converters and power supply systems for critical applications.

Druzinnikov str. 1, Voronezh
394026, Russia
+7 473 200-87-80

1, bld. 2, BC "W Plaza 1",
office A403, Moscow
101000, Russia
+7 499 372-50-10

This datasheet is valid for the following units: MDVi1000-1V24; MDVi1000-1V28; MDVi1000-1V48; MDDi1000-1D24; MDDi1000-1D28; MDDi1000-1D48; MDVm1000-1V24; MDVm1000-1V28; MDVm1000-1V48; MDDm1000-1D24; MDDm1000-1D28; MDDm1000-1D48.