

300 Watts Charging Power

Two Stage Charging

Adjustable Float Voltage

Common Negative Design

Buck Topology



3 YEAR WARRANTY



BCD300 DC SOURCE BATTERY CHARGER

The BCD300 battery charger outputs up to 300 watts to charge a 12V or 24V battery system (1 or 2 banks) from any higher voltage between 20 and 45 volts. The source and the batteries under charge must share a common ground. Multiple stages of filtering reduce radiated or conducted noise to very low levels.

The two stage charging profile charges the batteries at a constant current until the battery voltage reaches the float voltage that the unit is set to and then the current into the batteries will taper off as necessary to maintain the batteries at the float voltage.

The unit can be left permanently connected without fear of overcharge or damage to the batteries. The adjustable float voltage feature allows the unit to be used for any type of lead-acid battery including lead acid and gel cell.

Available models

Input

24, 28, 32 & 36V

32 & 36V

Output

12V

24V

Applications

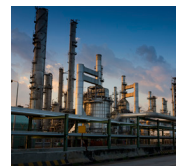

BCD300 | DC SOURCE BATTERY CHARGER

INPUT

Model Number	BCD300-32-12	BCD300-32-24
Input Volts Nominal	24, 28, 32 and 36 Volts	32 and 36 Volts
Input Volts Actual	20 - 45	30 - 45
Input Amps (max)	20	22
Input Fuse (AGC)	25A	
Noise on Input	<10 mV	
Low Input Voltage Alarm	10.5 V	

OUTPUT

Output Volts Nominal	12	24
Output Volts Actual	13.6 ± 0.05	27.2 ± 0.05
Charging Current (amps)	25	20
Output Adjustment	± 0.5 V	+/- 1.0 V
Output Crowbar	16.0 ± 0.5 V	32.0 ± 1.0 V
Output Fuse (AGC)	30 A x 2	25 A x 2
Output Ripple & Noise	< 10 mV	
Battery Banks	1 or 2	
Charging Stages	2	
Battery Size (Amp Hours)	100 - 150	80 - 120
Regulation (Line & Load)	< +/- 0.5%	
Duty Cycle	Continuous 100% for 24 hours per day	
Efficiency	> 85% @ Maximum Output	

MECHANICAL

Dimensions	9.1 in / 23.1 cm Long x 7.8 in / 19.8 cm Wide x 2.5 in / 6.4 cm High
Clearance	1.0 in / 2.5 cm all around
Weight	4.0 lb / 1.8 kg
Material and Finish	Marine Grade Black Anodized Aluminum Chassis c/w 18-8 Stainless Fasteners
Mounting	Wall or Shelf Mount
Connections	#12 AWG Input Wires (Positive & Negative). Four contact output terminal

ENVIRONMENTAL AND SAFETY

Operating Temperature Range	-25°C to +40°C @ maximum output. Derate Linearly 2.5% per °C from 40°C (Optional -40°C wide temperature range available)
Humidity	0 - 95% Relative Humidity (non-condensing) with standard conformal coating
Audible Noise	NONE 0db @ 3ft
Typical Service Life	> 10 years (87,600 hrs)
Isolation	Input – Output Common Negative, Input or Output – Case 500 VDC
Warranty	Three years parts and labor

OPTIONS

European ROHS compliant
(Lead Free Manufactured)

Electric Fork Lift
(Filtering and Surge Suppression)

Open frame
(No chassis, just heat sink bars)

Safety Special Inspection (CSA/UL)

Heavy duty ruggedization with wide temperature range

Custom input/output available

DIMENSIONS

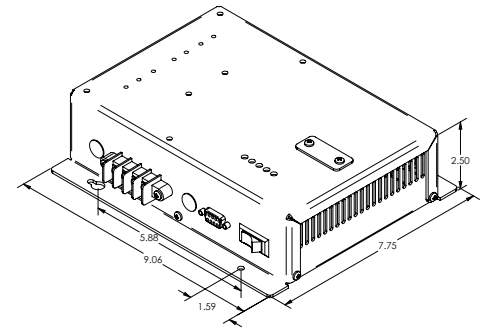

ANALYTIC SYSTEMS
Power Conversion Solutions



AnalyticSystems.com



sales@analyticsystems.com



604.946.9981 800.668.3884



8128 River Way
Delta BC V4G 1K5