



SIPSMT20W-12 SERIES

20 AMP

POL CONVERTERS



FEATURES

- * Non-isolated POL Converter
- * SIP / SMT Package
- * Output Current 20AMP
- * Input Voltage Range 6-14VDC
- * Output Voltage Range 0.7525-5VDC
- * 300KHz Switching Frequency
- * High Efficiency to 94%
- * Over Temperature Protection
- * Continuous Short Circuit Protection
- * Remote ON/OFF Control
- * Output Voltage Sequencing
- * Power Good Signal
- * UL/C-UL60950 Certified

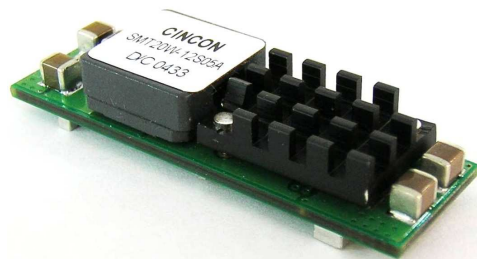
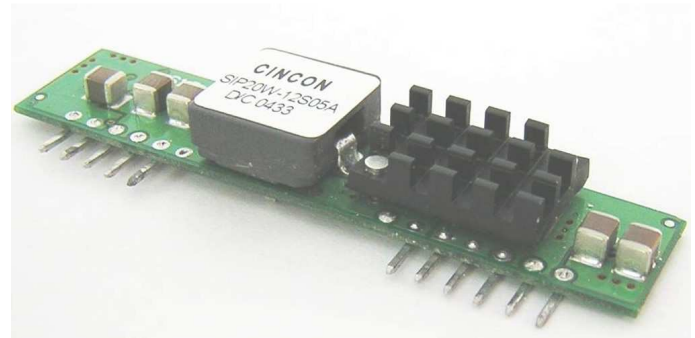

MODEL NUMBER	INPUT VOLTAGE	OUTPUT VOLTAGE	OUTPUT CURRENT	INPUT CURRENT		Efficiency (%)
				NO LOAD	FULL LOAD	
SIP20W-12S05A SMT20W-12S05A	6.0 – 14VDC	0.7525VDC	20A	40mA	1603mA	78
		1.2VDC	20A	50mA	2381mA	84
		1.5VDC	20A	50mA	2874mA	87
		1.8VDC	20A	50mA	3409mA	88
		2.0VDC	20A	60mA	3745mA	89
		2.5VDC	20A	65mA	4630mA	90
		3.3VDC	20A	75mA	5978mA	92
6.5 – 14VDC	5.0VDC	20A	95mA	8865mA	94	

NOTE: Nominal Input Voltage 12VDC

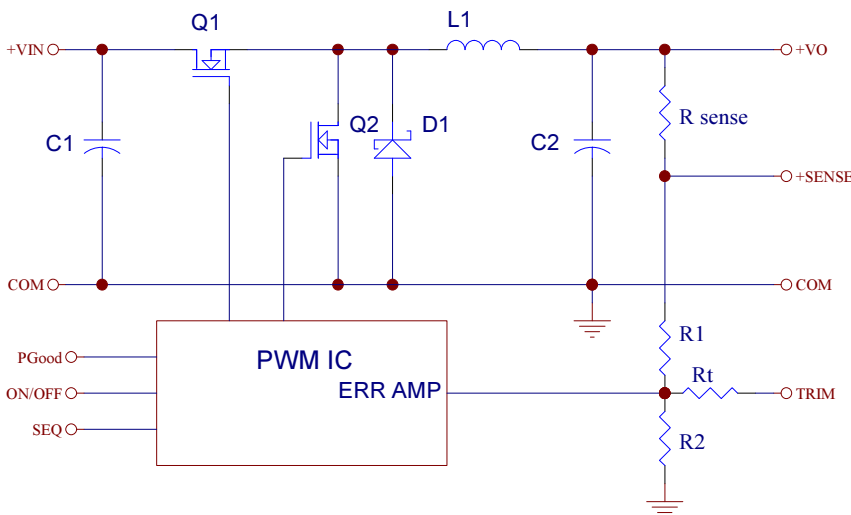

Vo,set (V)	Rtrim (KΩ)
0.7525	Open
1.2	22.46
1.5	13.05
1.8	9.024
2.0	7.417
2.5	5.009
3.3	3.122
5.0	1.472

Table 1. External Resistor Values for programming output voltage

Figure 1. Simplified Schematic

SPECIFICATIONS

All Specifications Typical At Nominal Line, Full Load, and 25°C Unless Otherwise Noted

INPUT SPECIFICATIONS:

Input Voltage Range.....	12V	6.0 – 14.0V
	12V	6.5 – 14.0V
Under Voltage Lock-out	Power up	5.0V typ.
	Power down	4.0V typ.
Input Filter Type	Capacitive	
Positive Remote on/off Control :		
Module ON	Open Circuit or = Vin	
Module OFF	< 0.4 Vdc	

OUTPUT SPECIFICATIONS:

Voltage Accuracy	±1.5% max.
Transient Response: 25% Step Load Change	<200us
Ripple and Noise, 20MHz BW (note 3)	30mV rms max.
	75mV pk-pk max.
Temperature Coefficient	±0.03%/C max.
Short Circuit Protection	Continuous
Line Regulation (note 1)	±0.2% max.
Load Regulation (note 2)	±0.5% max.
External Trim Adj. Range (see Table1).....	Vo=0.75 – 5.0Vdc
Sequencing Slew Rate Capability (dV _{SEQ} /dt)	0.1 – 1.0V/msec
Sequencing Delay Time	10msec min.
Tracking Accuracy .. Power up:200mV max., Power down:400mV max.	
Capacitive Load Low ESR	8000uF max.
Power Good Signal Asserted Logic High	Vo=90%-110%Vo, nom.
Start up time	7ms typ.

Dimensions:

SIP Packages

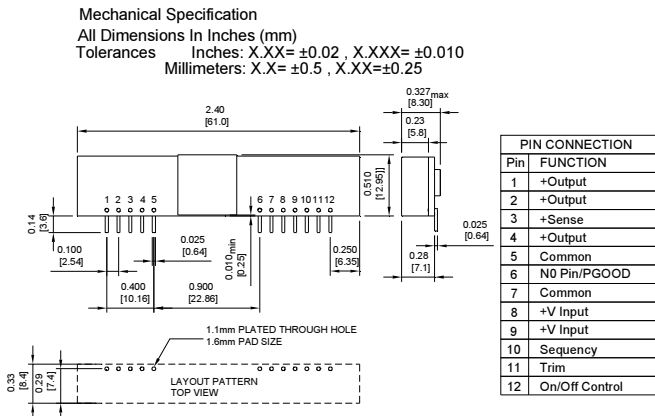

GENERAL SPECIFICATIONS:

Efficiency	See Table
Isolation Voltage	Non-isolation
Switching Frequency	300KHz typ.
Over Temperature Protection	130°C typ.
Operating Ambient Temperature Range	-40°C to +85°C
Power Derating Curve	see Figure2, 3
Storage Temperature Range	-55°C to +125°C
MTBF	MIL-STD-217F, GB, 25°C, Full Load
	0.9Mhrs typ.

Dimensions:

SIP Package:	2.40 x 0.510 x 0.327 inches (61.0 x 12.95 x 8.30 mm)
SMT Package:	1.70 x 0.530 x 0.366 inches (43.2 x 13.46x 9.30 mm)
Structure	Non-potted With Open Frame Type
Weight	11g

NOTE :

1. Measured From High Line to Low Line, Vo,set=3.3Vdc
2. Measured From Full Load to Zero Load, Vo,set=3.3Vdc
3. The output noise is measured with 10uf tantalum capacitor and 1uf ceramic capacitor across output.
4. The Input Terminal Recommend to Parallel With 200uF Capacitor ESR<25mΩ to Reduce The Input Ripple Voltage
5. Suffix "N" to the Model Number with Negative Logic Remote on/off
 Model ON

SMT Packages

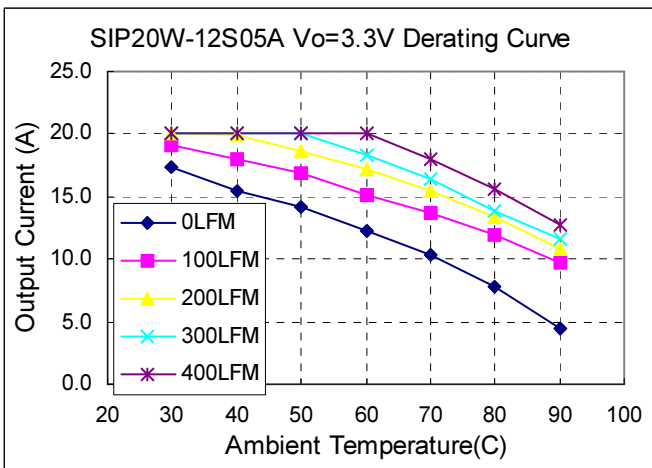
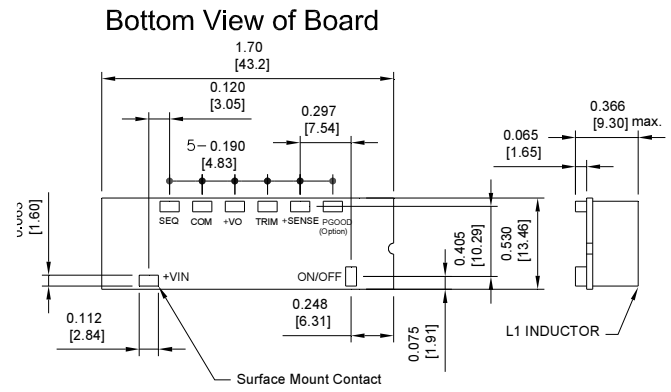

Figure2. Typical Power De-rating for 12V IN

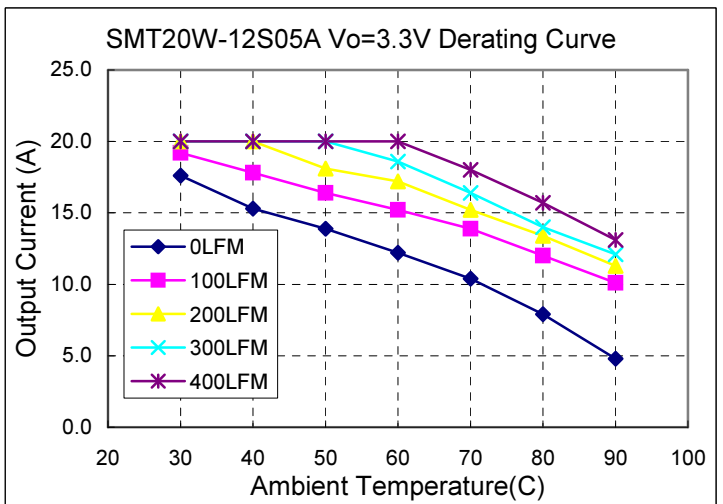

Figure3. Typical Power De-rating for 12V IN