



# Industrial DC/DC CONVERTER MGDI-26 Wide Input : 25W POWER

Industrial Grade ■

**4:1 Wide Input  
Single Output  
Metallic Case - 1.500 VDC Isolation**

- Wide input range
- Nominal power of 25 W
- Wide temperature range : -40°C/+95°C case
- Soft start
- Galvanic isolation 1.500 VDC according to EN60950
- Integrated LC EMI filter
- No load to full load operation
- Permanent short circuit protection
- No optocoupler for high reliability
- RoHS process



## 1-General

The MGDI-26 series is a complete line of DC/DC power modules designed for use in distributed power architecture and are particularly suitable for mobile or ground fixed applications in transportation, industrial and telecommunication areas. These modules use a high frequency fixed switching technic at 1MHz providing excellent reliability, low noise characteristics and high power density. Standard models are available with wide input voltage range of 9-36 or 16-40 volts. The series include single output voltage choices of 3,3, 5, 12 and 15 volts.

The MGDI-26 series is designed in conformity with safety standards EN60950 and UL1950. All the modules are designed with LC network filters to minimize reflected input current ripple

and output voltage ripple according to EN55022 and FCC Part 15J standard.

The modules include a soft-start, an input undervoltage lock-out and a permanent short circuit protection to ensure efficient module protections. The soft-start allows current limitation and eliminates inrush current during start-up. The short circuit protection completely protects the modules against short-circuits of any duration by a shut-down and restores to normal when the overload is removed.

The design has been carried out with surface mount components and is manufactured in a fully automated process to guarantee high quality. Every module is tested with a GAIA converter automated test equipment.

5

## 2-Product Selection

Single output model : MGDSI - 26 -  -

### Input Voltage Range

	Permanent	Transient
H :	9-36 VDC	40 VDC/100 ms
J :	16-40 VDC*	45 VDC/100 ms

\* for 45 Vdc consult factory

### Output

B : 3.3 VDC  
C : 5 VDC  
E : 12 VDC  
F : 15 VDC

## 2- Product Selection (continued)

Input range	Output	Current	Reference	Options
9-36 VDC	3,3 VDC	6 A	MGDSI-26-H-B	/
9-36 VDC	5 VDC	5 A	MGDSI-26-H-C	/
9-36 VDC	12 VDC	2,08 A	MGDSI-26-H-E	/
9-36 VDC	15 VDC	1,65 A	MGDSI-26-H-F	/
16-40 VDC	3,3 VDC	6 A	MGDSI-26-J-B	/
16-40 VDC	5 VDC	5 A	MGDSI-26-J-C	/
16-40 VDC	12 VDC	2,08 A	MGDSI-26-J-E	/
16-40 VDC	15 VDC	1,65 A	MGDSI-26-J-F	/

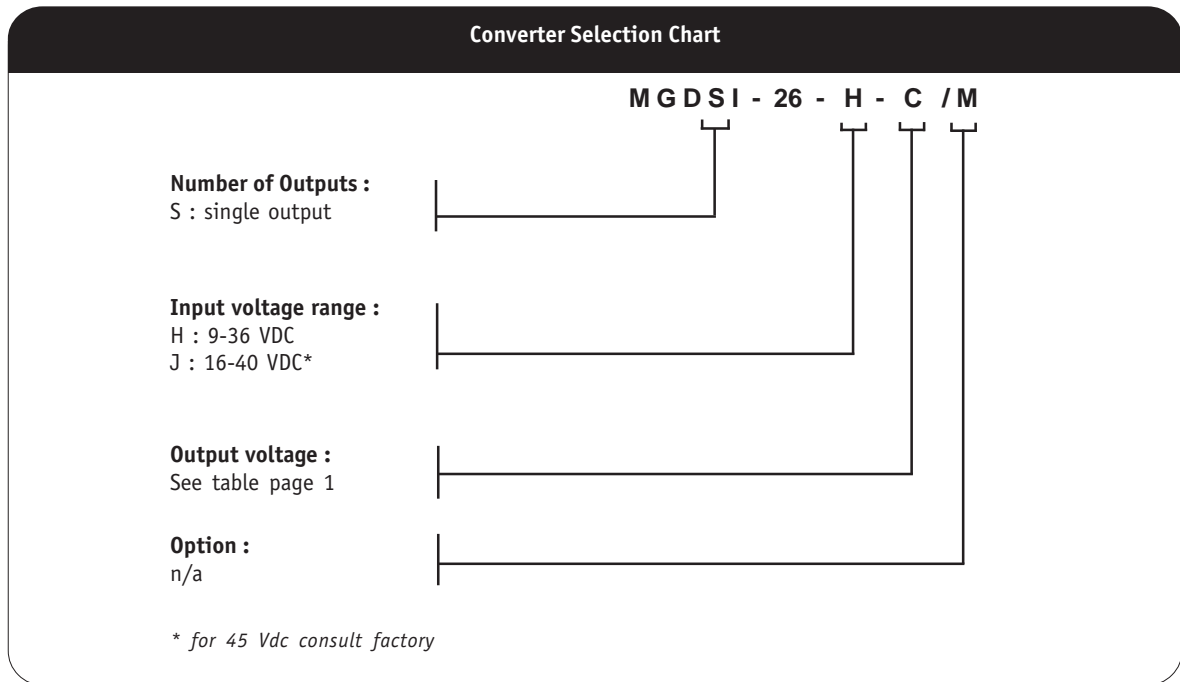

### 3- Electrical Specifications

Data are valid at +25°C, unless otherwise specified.

Parameter	Conditions	Limit or typical	Units	Single Output MGDSI-26	
				26 - H	26 - J
<b>Input</b>					
Nominal input voltage	Full temperature range	Nominal	VDC	20	24
Permanent input voltage range (Ui)	Full temperature range	Min. - Max.	VDC	9-36	16-40
Extended permanent input voltage range	Full temperature range (Consult factory)	Min. - Max.	VDC	/	16-45
Transient input voltage	Full load	Maximum	VDC/S	40/0,1	45/0,1
Undervoltage lock-out (UVLO)	Turn-on voltage	Nominal	VDC	8,5	15,5
	Turn-off voltage	Nominal	VDC	7,5	14,5
Start up time	Ui nominal Nominal output Full load : resistive	Maximum	ms	30	30
Reflected ripple current	Ui nominal, full load at switching freq. BW = 20MHz	Maximum	mApp	50	50
Input current in short circuit mode (Average)	Ui nominal Short-circuit	Maximum	mA	35	35
No load input current	Ui nominal No load	Maximum	mA	35	35
Input current in inhibit mode	Ui nominal No load	Maximum	mA	25	25
<b>Output</b>					
Output voltage	Full temperature range	Nominal	VDC	3,3	3,3
	Ui min. to max.	Nominal	VDC	5	5
	75% load	Nominal	VDC	12	12
		Nominal	VDC	15	15
Set Point accuracy	Ambient temperature : +25°C Ui nominal, 75% load	Maximum	%	+/- 2	+/- 2
Output power	Full temperature range Ui min. to max.	Maximum	W	25	25
Output current *		Maximum	A	6	6
3,3V output	Full temperature range Ui min. to max.	Maximum	A	5	5
5V output		Maximum	A	2,1	2,1
12V output		Maximum	A	1,65	1,65
15V output		Maximum	A	1,65	1,65
Ripple output voltage 3,3V and 5V output 12V output 15V output	Ui nominal	Maximum	mVpp	50	50
	Full load	Maximum	mVpp	50	50
	BW = 20MHz	Maximum	mVpp	60	60
		Maximum	mVpp	60	60
Line regulation	Ui min. to max. Full load	Maximum	%	+/- 1	+/- 1
Load regulation	Ui nominal 25% to full load	Maximum	%	+/- 2	+/- 2
Output voltage trim	As function of output voltage	Maximum	%	- 20	- 20
		Minimum	%	+10	+ 10
Efficiency	Ui nominal Full load	Typical	%	80	80
Maximum admissible Capacitive load					
3,3V output	Full input voltage range	Maximum	µF	4 700	4 700
5V output	Full load	Maximum	µF	1 000	1 000
12V output	Per output	Maximum	µF	330	330
15V output		Maximum	µF	250	250

Note \* : For 9-36V input range, the current is derated at 80% at 9V and increases linearly to full current at 12V.

## 4- Switching Frequency

Parameter	Conditions	Limit or typical	Specifications
Switching frequency	Full temperature range Ui min. to max. No load to full load	Nominal, fixed	1 MHz

## 5- Isolation

Parameter	Conditions	Limit or typical	Specifications
Electric strength test voltage	Input to output	Minimum	1 500 VDC / 1 min
	Input to case	Minimum	500 VDC / 1 min
	Output to case	Minimum	1 500 VDC / 1 min
Isolation resistance	500 VDC	Minimum	100 M0hm

## 6- Protection Functions

Characteristics	Protection Device	Recovery	Limit or typical	Specifications
Input undervoltage lock-out (UVLO)	Turn-on, turn-off circuit with hysteresis cycle	Automatic recovery	Turn-on nominal Turn-off nominal	See section 3
Output short circuit protection (SCP)	Hiccup circuitry with auto-recovery	Automatic recovery	Permanent	See section 10

**5**

## 7- Reliability Data

Characteristics	Conditions	Temperature	Specifications
Mean Time Between Failure (MTBF) According to MIL-HDBK-217F	Ground fixed (Gf)	Case at 40°C Case at 70°C	750 000 Hrs 295 000 Hrs
	Ground mobile (Gm)	Case at 40°C Case at 70°C	Consult factory Consult factory
Mean Time Between Failure (MTBF) According to IEC-62380-TR	Railway, Payphone	Ambient at 25°C 100% time in	225 000 Hrs

## 8- Thermal Characteristics

Characteristics	Conditions	Limit or typical	Performances
Operating ambient temperature range at full load	Ambient temperature *	Minimum Maximum	- 40°C + 71°C
Operating case temperature range at full load	Case temperature	Minimum Maximum	- 40°C +95°C
Storage temperature range	Non functioning	Minimum Maximum	- 40°C + 105°C
Thermal resistance	Rth case to ambient in free air natural convection	Typical	7°C /W

Note \* : The upper temperature range depends on configuration, the user must assure a max. case temperature of + 95°C.

The MGDI-26 series operating **case** temperature must not exceed 95°C. The maximum **ambient** temperature admissible for the DC/DC converter corresponding to the maximum operating case temperature of 95°C depends on the ambient airflow, the mounting/orientation, the cooling features and the power dissipated.

To calculate a maximum admissible ambient temperature the following method can be used. Knowing the maximum case temperature  $T_{case} = 95^\circ\text{C}$  of the module, the power used  $P_{out}$  and the efficiency  $\eta$  :

- determine the power dissipated by the module  $P_{diss}$  that should be evacuated :

$$P_{diss} = P_{out}(1/\eta - 1)$$

- determine the maximum ambient temperature :

$$T_a = 95^\circ\text{C} - R_{th} \times P_{diss}$$

where **Rth** is the thermal resistance from the case to ambient.

The previous thermal calculation shows two areas of operation :

- a normal operation area in a free natural ambient convection (grey area in this following graph),
- an area with cooling features (air flow or heatsink) ensuring a maximum case temperature below the maximum operating case temperature of 95°C (white area in the following graph).

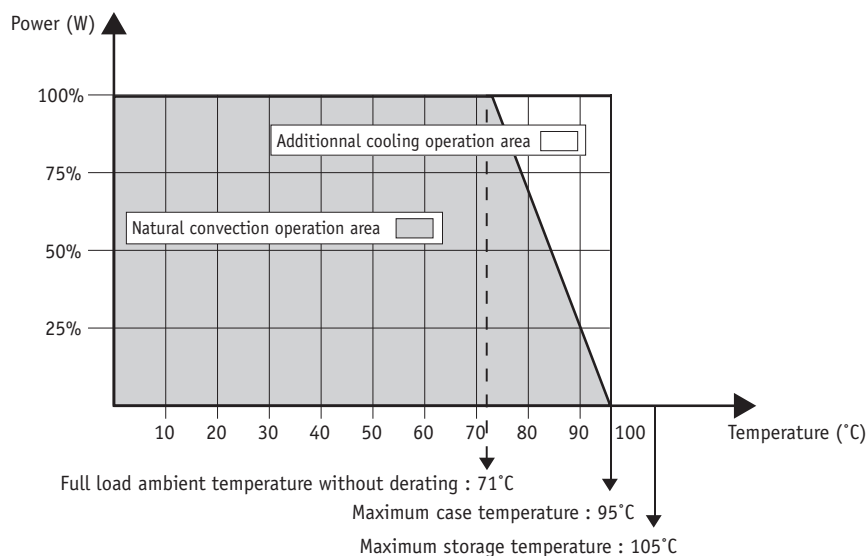

## 9- Environmental Qualifications

The modules have been subjected to the following environmental qualifications.

Characteristics	Conditions	Severity	Test procedure
<b>Climatic Qualifications</b>			
Life at high temperature	Duration Temperature Status of unit	1 000 Hrs 95°C case unit operating	IEC 68-2-2
Humidity steady	Damp heat Temperature Duration Status of unit	93 % relative humidity 40°C 56 days unit not operating	IEC 68-2-3 Test Ca
Temperature cycling	Number of cycles Temperature change Transfert time Steady state time Status of unit	200 -40°C / +71°C 40 min. 20 min. unit not operating	IEC 68-2-14 Test N
Temperature shock	Number of shocks Temperature change Transfert time Steady state time Status of unit	50 -40°C / +105°C 10 sec. 20 min. unit not operating	IEC 68-2-14 Test Na
<b>Mechanical Qualifications</b>			
Vibration (Sinusoidal)	Number of cycles Frequency : amplitude Frequency : acceleration Amplitude /acceleration Duration Status of unit	10 cycles in each axis 10 to 60 Hz / 0.7 mm 60 to 2000 Hz / 10 g 0.7 mm/10 g 2h 30 min. per axis unit not operating	IEC 68-2-6 Test Fc
Shock (Half sinus)	Number of shocks Peak acceleration Duration Shock form Status of unit	3 shocks in each axis 100 g 6 ms 1/2 sinusoidal unit not operating	IEC 68-2-27 Test Ea
Bump (Half sinus)	Number of bumps Peak acceleration Duration Status of unit	2 000 bumps in each axis 25 g 6 ms unit not operating	IEC 68-2-29 Test Eb
<b>Electrical Immunity Qualifications</b>			
Electrical discharge susceptibility	Number of discharges Air discharge level Contact discharge level Air discharge level Contact discharge level	10 positive & 10 negative discharges 4 kV : sanction A 2 Kk : sanction A 8 Kk : sanction B 4 kV : sanction B	EN55082-2 with : EN61000-4-2 IEC 801-2
Electrical field susceptibility	Antenna position Electromagnetic field Wave form signal Frequency range	at 1 m 10 V/m AM 80%, 1 kHz 26 MHz to 1 GHz	EN55082-2 with : EN61000-4-3 IEC801-3
Electrical fast transient susceptibility	Burst form Wave form signal Impedance Level 1 Level 3	5/50 ns 5 kHz with 15 ms burst duration period 300 ms 50 Ohm 0,5 kV : sanction A 2 kV : sanction B	EN55082-2 with : EN61000-4-4 IEC801-4

## 10- Description of Protections

### 10-1 Input Undervoltage Lock-out (UVLO)

An input undervoltage protection will inhibit the module when input voltage drops below the lock-out turn-off threshold (see section 3 for value) and restores to normal operation automatically when the input voltage rises the lock-out turn-on threshold.

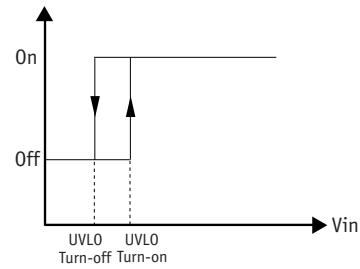

### 10-2 Output Short Circuit Protection (SCP)

The short circuit protection device protects the module against short circuit of any duration and restores the module to normal operation when the short circuit is removed. It operates in «hiccup» mode by testing periodically if an overload is applied (typically every 1s recovery time). The overload detection threshold is typically 200% of maximum current with a detection time lower than 5ms.

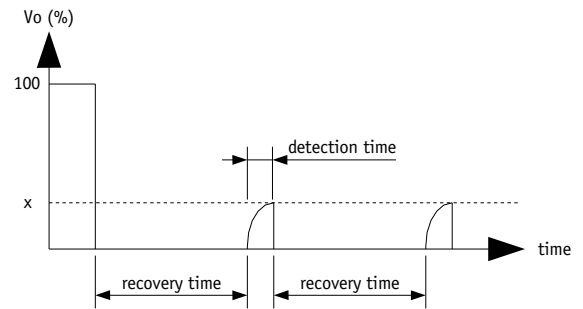

## 11- Description of Functions

### 11-1 Trim Function

The primary output voltage  $V_o$  may be trimmed at  $-20\%/+10\%$  via a single external trimpot or fixed resistor. The trimpot should be connected as shown in figure hereafter. Value of the trim resistance is given in the following table.

$V_o$	P1 Value
3,3 V	4,7 KOhm
5 V	10 KOhm
12 V	12 KOhm
15 V	22 KOhm

*For other  $V_o1$  Output value consult Factory*

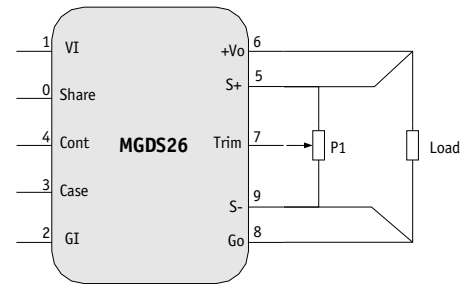

### 11-2 Sense Function

If the load is separated from the output by any line length, some of these performance characteristics will be degraded at the load terminals by an amount proportional to the impedance of the load leads. Sense connections enable to compensate the line drop at a maximum of  $\pm 10\%$  of output voltage. Connection is described in figure herein.

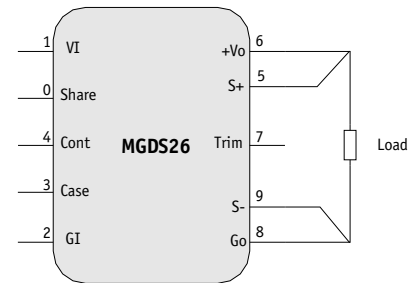

### 11-3 On/Off Function

The control pin 4 (On/Off) can be used for applications requiring On/Off operation. This may be done with an open collector transistor, a switch, a relay or an optocoupler. Several converters may be disabled with a single switch by connecting all On/Off pins together.

- The converter is disabled by pulling low the pin 4.
- No connection or high impedance on pin 4 enables the converter.

By releasing the On/Off function, the converter will restart within the start up time specifications given in table section 4. For further details please consult "Logic On/Off" application note.

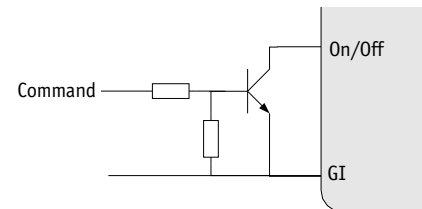

### 11-4 Synchronization Function

The MGDM-26 series provide a bi-directional synchronization function through pin 4 (CONT) to enable automatic synchronization between several converters. The converters lock into the highest switching frequency if more than one converter is used or on an external clock for a frequency in the range between  $105\%$  and  $115\%$  of the converter's free frequency.

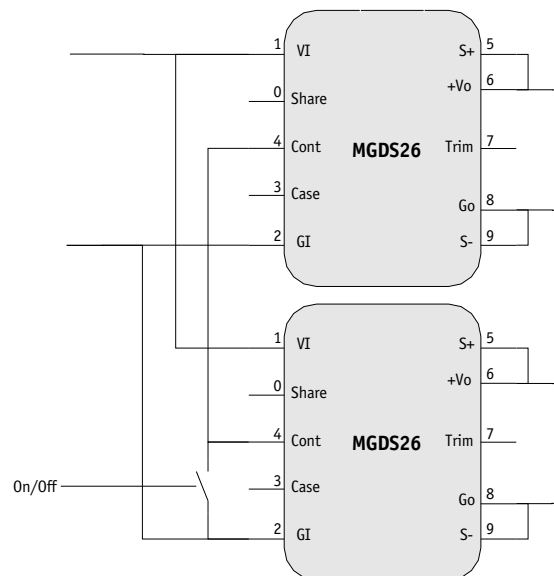



## 12- Application Notes

### 12-1 Connection of Modules in Series

The output of single output units can be connected in series without any precautions to provide higher output voltage level.

Nevertheless, GAIA Converter recommends to protect each individual output by a low power shottky diode rated with the maximum current of the converter to avoid reverse polarity at any output.

Reverse polarity may occur at start up if the output voltages do not rise at the same time.

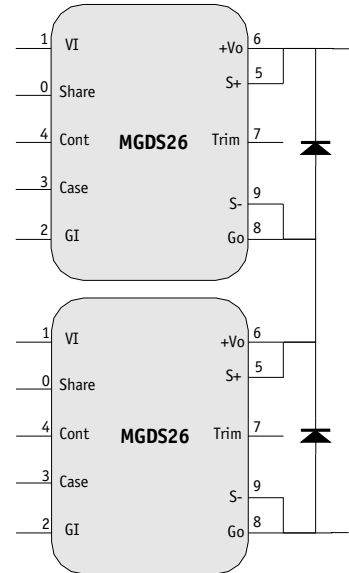

### 12-2 Connection of Modules in Parallel

The MGDI-26 series features parallel (load sharing) operations to increase output power with a true N+1 redundancy. Up to 4 converters can be parallelized through the "SHARE" pins as described in the following schematic.

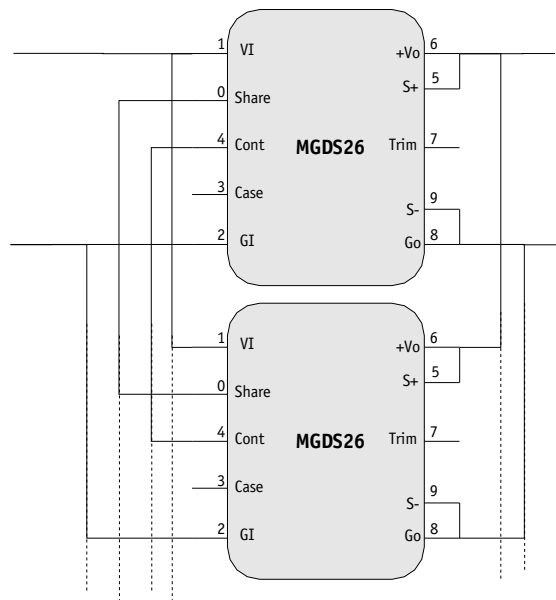

5

### 13- Dimensions

Dimension are given in mm (inches). Tolerance : +/- 0,2 mm (+/- 0.01 ") unless otherwise indicated.  
Weight : 65 grams (2.3 Ozs) max.

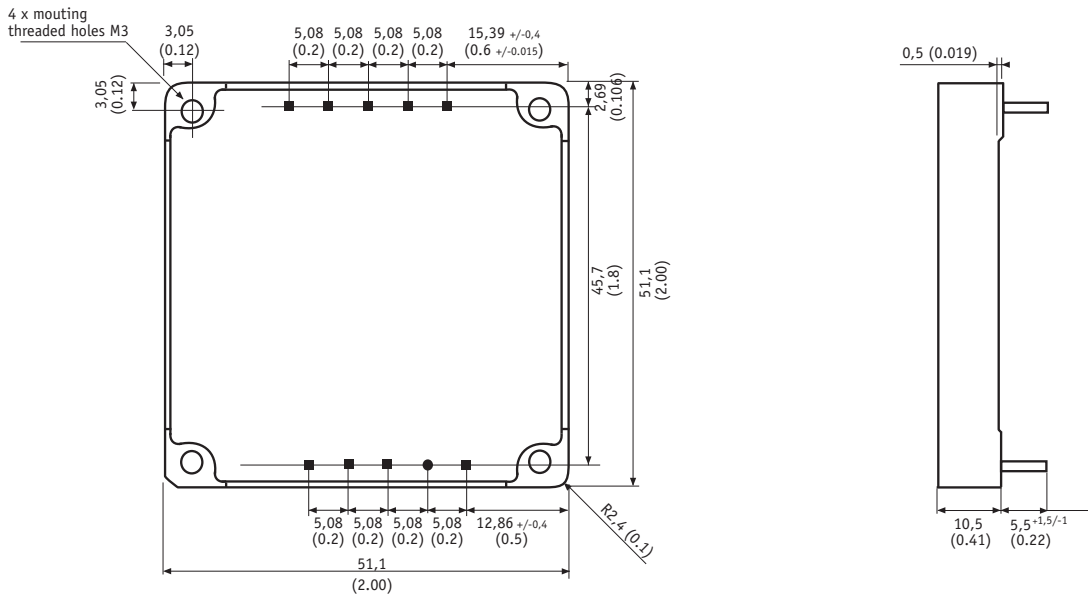

Pin 3 : round pin  $\varnothing$  0,83 mm (0.032") length : 4<sup>+/-1</sup> mm  
All other pins : square pin  $\varnothing$  0,91mm (0.036") length : 5,5<sup>+1,5/-1</sup> mm

### 14- Materials

Case : Metallic black anodized coating  
Pins : Plated with pure matte tin over nickel underplate

### 15- Product Marking

Upper face : Company logo, location of manufacturing.  
Side face : Module reference, option, date code : year and week of manufacturing.

### 16- Connections

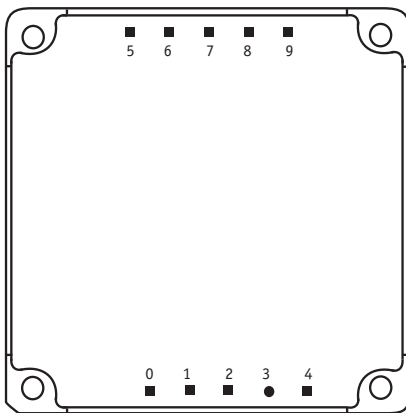

Bottom view

Pin	Single
0	Share
1	+ Input (Vi)
2	- Input (Gi)
3	Case
4	Control (Cont)
5	Sense + (S +)
6	+ Output (Vo)
7	Trim (Trim)
8	- Output (Go)
9	Sense - (S -)



For more detailed specifications and applications information, contact :

**International Headquarters**

GAIA Converter - France  
ZI de la Morandière  
33185 LE HAILLAN - FRANCE  
Tel. : + (33)-5-57-92-12-80  
Fax : + (33)-5-57-92-12-89

**North American Headquarters**

GAIA Converter Canada, Inc  
4038 Le Corbusier Blvd  
LAVAL, QUEBEC - CANADA H7L 5R2  
Tel. : (514)-333-3169  
Fax : (514)-333-4519

Represented by :